

STILT FLOOR PLAN

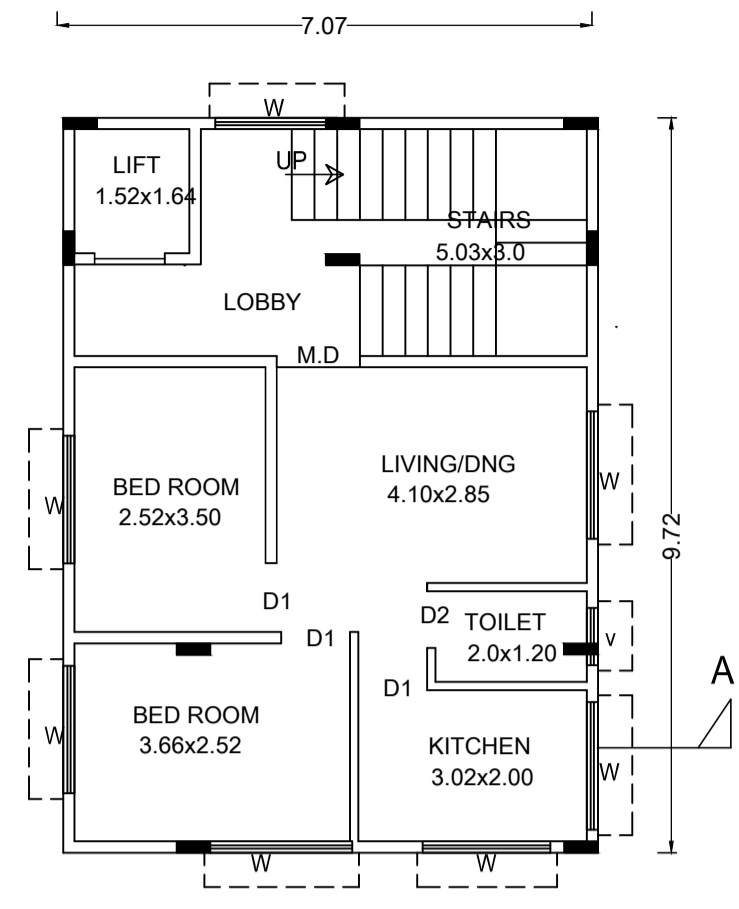

GROUND FLOOR PLAN

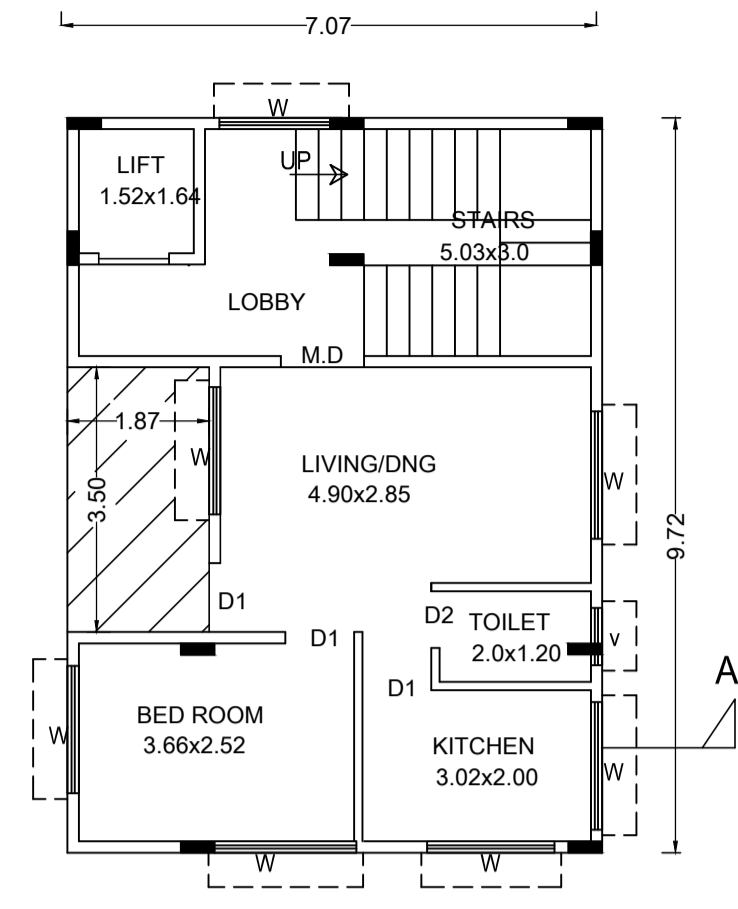

FIRST FLOOR PLAN

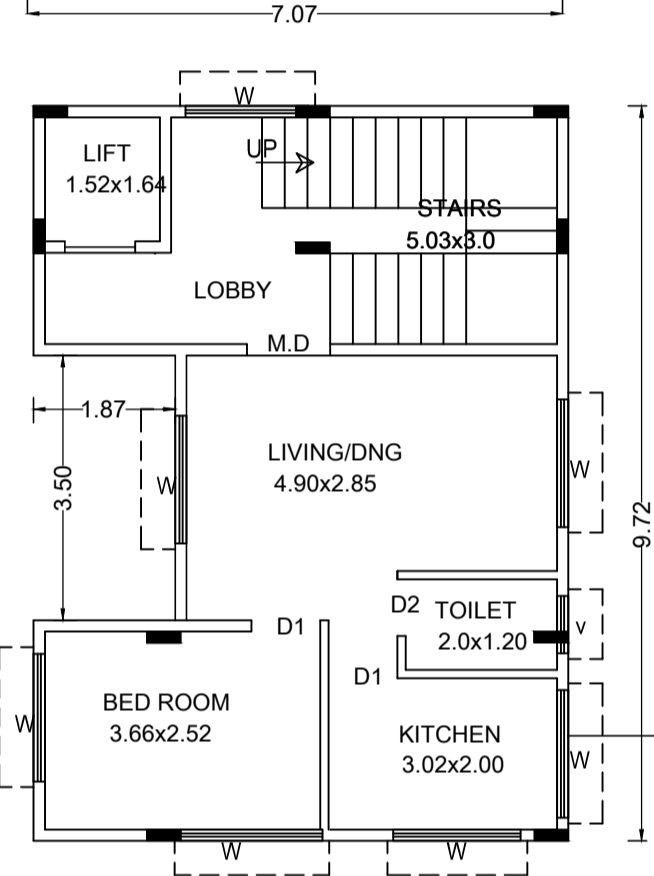

SECOND FLOOR PLAN

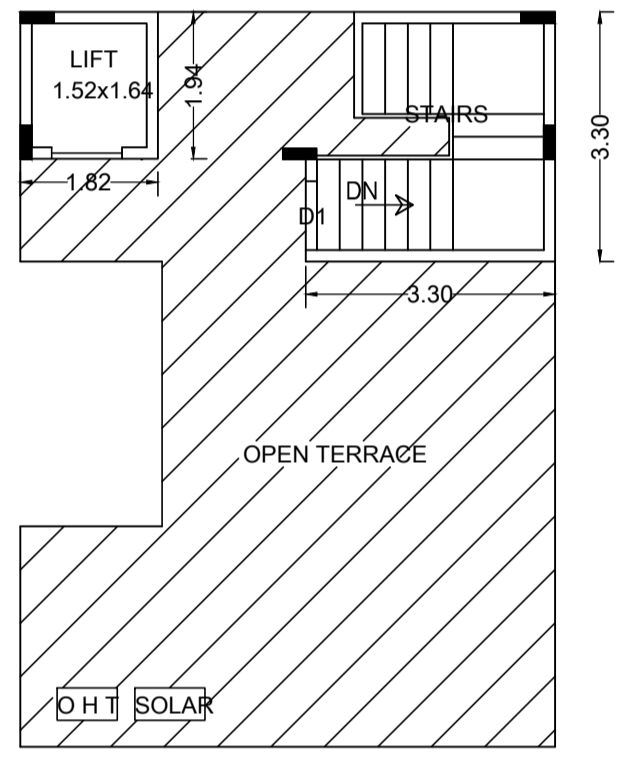

TERRACE FLOOR PLAN

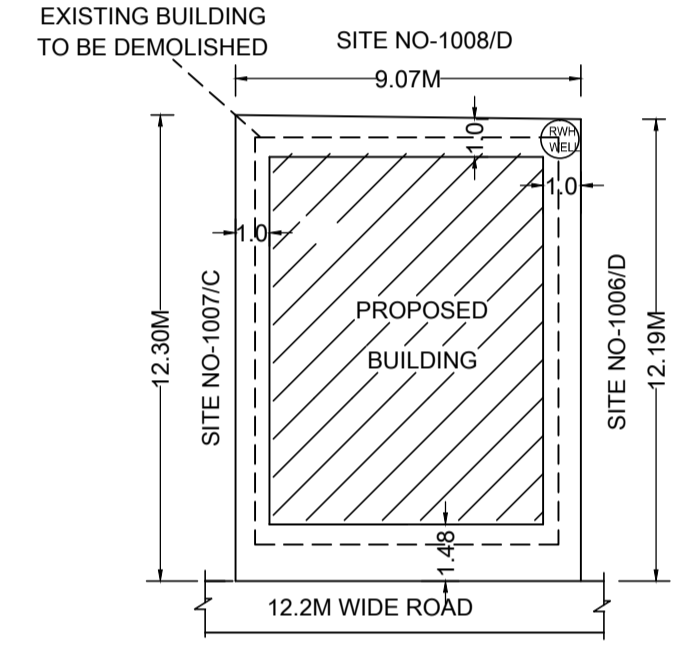

SITE PLAN

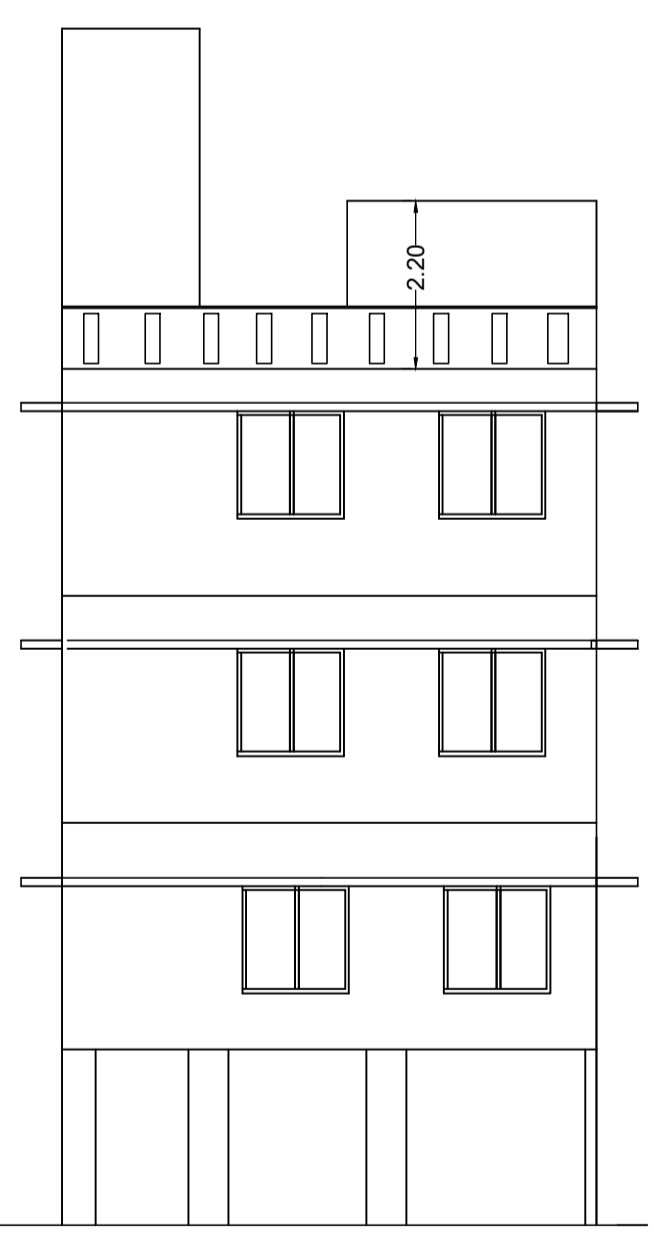

FRONT ELEVATION

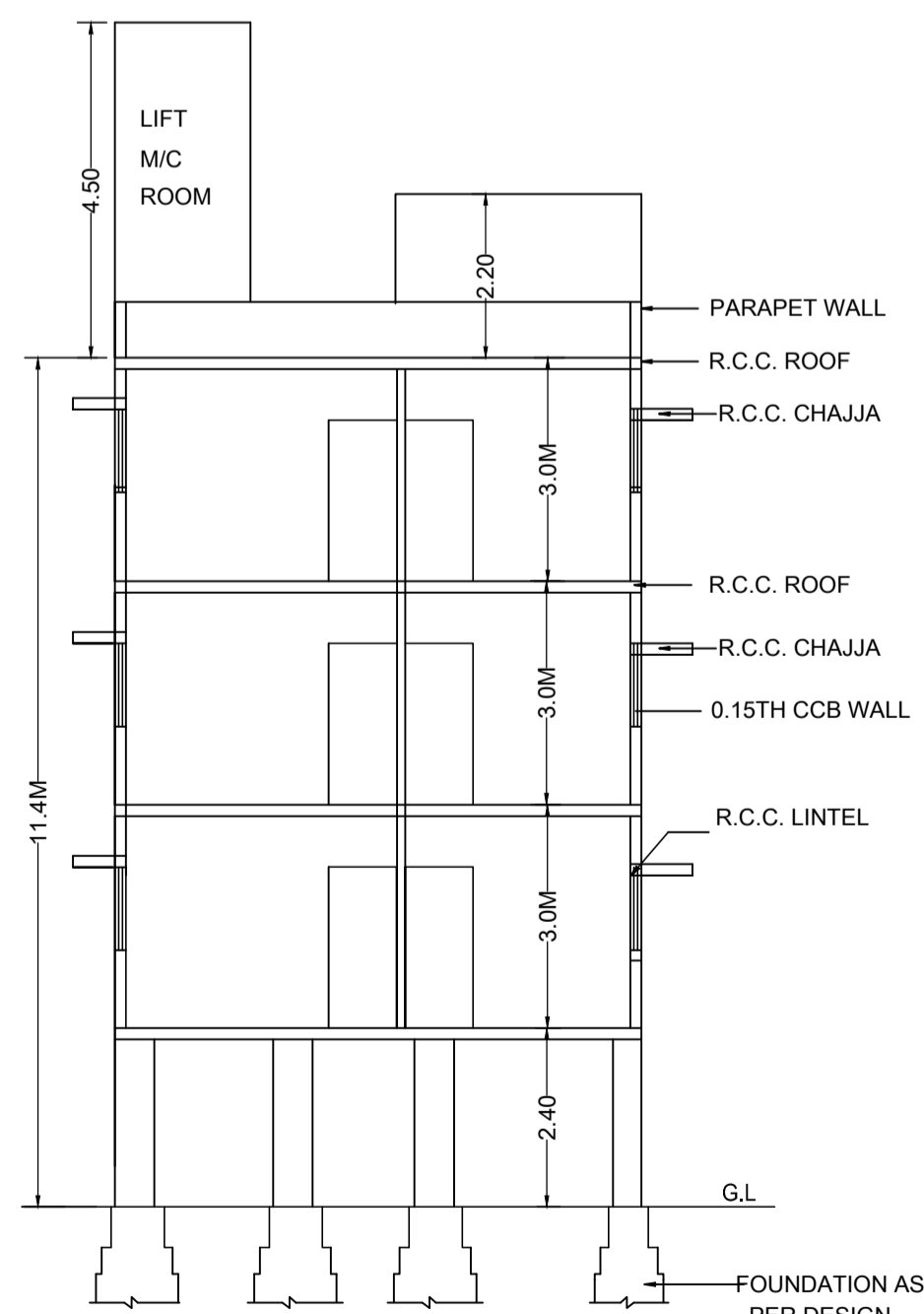

SECTION AT 'AA'

- Approval Condition : This Plan Sanction is issued subject to the following conditions : 1. Sanction is accorded for the Residential Building at 1007/D, BINNAMANGALA 2ND STAGE, Bangalore. 2. Consist of 1Stilt + 1Ground + 2 only. 3. Sanction is accorded for Residential use only. 4. Development charges towards increasing the capacity of water supply, sanitary and power main has to be paid to BWSSB and BESCOM if any. 5. Necessary ducts for running telephone cables, cubicles at ground level for postal services & space for dumping garbage within the premises shall be provided. 6. The applicant shall INSURE all workmen involved in the construction work against any accident / untoward incidents arising during the time of construction. 7. The applicant shall not stock any building materials / debris on footpath or on roads or on drains. The debris shall be removed and transported to near by dumping yard. 8. The applicant shall maintain during construction such barricading as considered necessary to prevent dust, debris & other materials endangering the safety of people / structures etc. in & around the site. 9. The applicant shall plant at least two trees in the premises. 10. Permission shall be obtained from forest department for cutting trees before the commencement of the work. 11. License and approved plans shall be posted in a conspicuous place of the licensed premises. The building license and the copies of sanctioned plans with specifications shall be mounted on a frame and displayed and they shall be made available during inspections. 12. If any owner / builder contravenes the provisions of Building Bye-laws and rules in force, the Architect / Engineer / Supervisor will be informed by the Authority in the first instance, warned in the second instance and cancel the registration if the same is repeated for the third time. 13. Technical personnel, applicant or owner as the case may be shall strictly adhere to the duties and responsibilities specified in Schedule - IV (Bye-law No. 3.6) under sub section IV-8 (e) to (k). 14. The building shall be constructed under the supervision of a registered structural engineer. 15. On completion of foundation or footings before erection of walls on the foundation and in the case of columnar structure before erecting the columns "COMMENCEMENT CERTIFICATE" shall be obtained. 16. Drinking water supplied by BWSSB should not be used for the construction activity of the building. 17. The applicant shall ensure that the Rain Water Harvesting Structures are provided & maintained in good repair for storage of water for non potable purposes or recharge of ground water at all times having a minimum total capacity mentioned in the Bye-law 32(a). 18. If any owner / builder contravenes the provisions of Building Bye-laws and rules in force, the authority will inform the same to the concerned registered Architect / Engineers / Supervisor in the first instance, warn in the second instance and cancel the registration of the professional if the same is repeated for the third time. 19. The Builder / Contractor / Professional responsible for supervision of work shall not shall not materially and structurally deviate the construction from the sanctioned plan, without previous approval of the authority. They shall explain to the owner s about the risk involved in contravention of the provisions of the Act, Rules, Bye-laws, Zoning Regulations, Standing Orders and Policy Orders of the BBMP. 20. In case of any false information, misrepresentation of facts, or pending court cases, the plan sanction is deemed cancelled. Special Condition as per Labour Department of Government of Karnataka vide ADDENDUM (Hosadaagi/Hoodke) Letter No. LD/95/LET/2013, dated: 01-04-2013 :

COLOR INDEX table with 2 columns: COLOR INDEX and description (PLOT BOUNDARY, ABUTTING ROAD, PROPOSED WORK, EXISTING, EXISTING TO BE DEMOLISHED)

AREA STATEMENT (BBMP) table with columns: AREA STATEMENT (BBMP), VERSION NO., VERSION DATE, PROJECT DETAIL, AREA DETAILS, COVERAGE CHECK, FAR CHECK, BUILT UP AREA CHECK

Approval Date : 05/16/2020 3:15:56 PM

Payment Details table with columns: Sr No., Challan Number, Receipt Number, Amount (INR), Payment Mode, Transaction Number, Payment Date, Remark

- 1. Registration of Applicant / Builder / Owner / Contractor and the construction workers working in the construction site with the "Karnataka Building and Other Construction workers Welfare Board" should be strictly adhered to. 2. The Applicant / Builder / Owner / Contractor should submit the Registration of establishment and list of construction workers engaged at the time of issue of Commencement Certificate. 3. The Applicant / Builder / Owner / Contractor shall also inform the changes if any of the list of workers engaged by him. 4. At any point of time No Applicant / Builder / Owner / Contractor shall engage a construction worker in his site or work place who is not registered with the "Karnataka Building and Other Construction workers Welfare Board". 5. BBMP will not be responsible for any dispute that may arise in respect of property in question. 6. In case if the documents submitted in respect of property is found to be false or fabricated, the plan sanctioned stands cancelled automatically and legal action will be initiated.

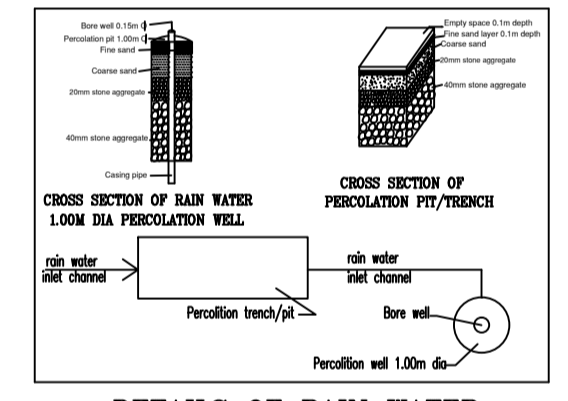

DETAILS OF RAIN WATER HARVESTING STRUCTURES

Block :A (R3) table with columns: Floor Name, Total Built Up Area, Deductions (Area in Sq.mt.), Proposed FAR Area, Total FAR Area, Tnmt (No.)

UnitBUA Table for Block :A (R3) table with columns: FLOOR, Name, UnitBUA Type, UnitBUA Area, Carpet Area, No. of Rooms, No. of Tenement

FAR & Tenement Details table with columns: Block, No. of Same Bldg, Total Built Up Area, Deductions (Area in Sq.mt.), Proposed FAR Area, Total FAR Area, Tnmt (No.)

Required Parking (Table 7a) table with columns: Block Name, Type, SubUse, Area (Sq.mt.), Units (Reqd., Prop.), Car (Reqd., Prop.)

Parking Check (Table 7b) table with columns: Vehicle Type, No., Area (Sq.mt.), Achieved (No., Area (Sq.mt.))

Block USE/SUBUSE Details table with columns: Block Name, Block Use, Block SubUse, Block Structure, Block Land Use Category

SCHEDULE OF JOINERY: table with columns: BLOCK NAME, NAME, LENGTH, HEIGHT, NOS

SCHEDULE OF JOINERY: table with columns: BLOCK NAME, NAME, LENGTH, HEIGHT, NOS

The plans are approved in accordance with the acceptance for approval by the Assistant Director of town planning (EAST) on date: 16/05/2020 vide lp number: BBMP/Ad.Com./EST/1538/19-20 subject to terms and conditions laid down along with this building plan approval. Validity of this approval is two years from the date of issue.

ASSISTANT DIRECTOR OF TOWN PLANNING (EAST) with signature and stamp of T.C. MAHADEVAIAH, Designation: Assistant Director Town Planning (ADTP), Organization: BRUHAT BANGALORE MAHANAGARA PALIKE, Date: 30-May-2020 17:45:27

BHRUHAT BENGALURU MAHANAGARA PALIKE

OWNER / GPA HOLDER'S SIGNATURE: OWNER'S ADDRESS WITH ID NUMBER & CONTACT NUMBER: A. VENKATESH AND V. PARVATHI NO-1007/D, BINNAMANGALA 2ND STAGE. Signatures of A. Venkatesh and V. Parvathi.

ARCHITECT/ENGINEER /SUPERVISOR 'S SIGNATURE: MEHBOOB BASHA 03,6TH CROSS, 5TH MAIN, VENKATARANGAPURAM, BANGALORE E-3150/2007-08. Stamp of M. Basha.

PROJECT TITLE : PLAN OF PROPOSED RESIDENTIAL BUILDING AT SITE NO-1007/D, SITUATED AT BINNAMANGALA 2ND STAGE, NEW WARD NO-80(82) , BANGALORE. PID NO: 82-24-1007/D

DRAWING TITLE : 1644328183-03-02-2020 10-47-55\$ _\$9M12M-SGFS--3U-OL-SIDDU

SHEET NO : 1